



# Digital Energy™ SitePro® Series UPS

Uninterruptible Power Supply 10 - 500 kVA



GE imagination at work

For more than a century, GE has led the way with innovative technologies and groundbreaking quality initiatives – literally helping to power the world. Along the way, through the development and delivery of state-of-the-art products and uncompromising service, GE has also built a legacy as a leading supplier of critical power solutions.

To bridge the gap between the traditional utility grid and the needs of today's business, GE offers a complete portfolio of critical power products and services, from desktop Uninterruptible Power Supply (UPS) units to engineered power systems, and from basic UPS and battery maintenance to comprehensive service contracts covering every aspect of your power quality and delivery system.

At GE, our goal is simple – to never let power quality stand in the way of our customers' success. That's why GE is committed to continue developing and delivering

**UPS technology for the digital world**

# The power of GE

Since the founding of the General Electric Company by Thomas Edison in 1882, GE Consumer & Industrial has been known for technical innovation. GE Consumer & Industrial has over 7,600 U.S. and foreign patents on products that help provide peace of mind for people, the properties they own and their workplaces. In 2001 alone, GE Consumer & Industrial filed more than 200 U.S. and 340 foreign patent applications.

GE Consumer & Industrial spans the globe as an industry leader in integrated industrial, electrical and security equipment, systems and services. The business brings to customers the latest technologies that are used to distribute, protect and control energy and equipment, and to provide premise management. GE provides innovative product and service solutions for commercial, industrial, residential and utility customers.

GE is proud of its impressive track record for introducing leading edge products, accomplishing growth, having strategic customer relationships and a global presence as broad and expansive as its portfolio of products. GE is committed to maintaining a leadership position in all four of its company-wide initiatives (Six Sigma, Globalization, e-Business/Digitization and Services) to achieve maximum results, whilst embracing the values that are at the heart of the business - imagine, solve, build and lead.

## UPS Product Technology

GE is a leader in the field of critical power protection. It's UPS Product Technology business designs, manufactures and delivers premium power quality products and related software products that ensure organisations all over the world enjoy a safe and managed power supply.

Protect your critical power application with a GE UPS – ranging from 350VA to 4MVA. Using state of the art technology GE has developed different UPS with high reliability and maximum application flexibility.

With a GE power solution in place, your mission-critical equipment is protected from any fluctuation in your power source, enabling you to concentrate on your core activities. Leave your critical power needs with GE, a reliable power quality supplier for more than 100 years.



Digital Energy™ SitePro® Series  
Uninterruptible Power Supplies  
10 - 500 kVA

The GE SitePro® family of high-performance UPS systems provides critical power protection for a wide range of applications. All SitePro models operate in a double conversion mode (providing true on-line operation), thus providing the highest levels of power reliability. Each UPS is fully compliant with international standards regarding Voltage and Frequency Independent (VFI) operation. True VFI makes the GE SitePro an extremely reliable UPS for data security and other demanding critical applications.

This continuous on-line UPS is available in models from 10 kVA up to 500 kVA. For high-power redundant applications, the GE SitePro can be installed with up to eight units in parallel, achieving power protection up to 4 MVA. The systems are controlled in a true peer-to-peer configuration with redundancy in all critical elements and functions utilizing GE's exclusive Redundant Parallel Architecture™ (RPA™) technology. This advanced technology provides the highest possible system reliability for mission critical applications with no single points of failure.



## applications

- Computer and data centres
- Medical equipment and healthcare facilities
- Call centres
- Broadcasting and satellite transmission systems
- Manufacturing and process control units
- Transportation infrastructure
- Security systems
- Financial institutions
- Fixed and mobile voice and data transmission

## superior battery management

- Temperature compensation, prevents overcharging
- Programmable battery test to prevent “surprises”
- Safe battery test by reduction of rectifier voltage instead of switching off rectifier
- Flexible number of elements allows for optimised battery solution
- Compatible with lead acid and nickel cadmium batteries
- Heavy duty charger also supports large battery capacities

## options

- Input/Output transformers
- Matching battery cabinets
- SNMP plug in card for integration into networks
- 12 pulse or 24 pulse digitally controlled rectifier
- Input filters for low input current harmonic distortion
- Remote monitoring panel
- Top cable entry box
- IP31 protection degree
- Halogen free cabling
- Non standard colours
- Redundant Parallel Architecture™

## ultimate safety

- Compliance to European UPS standard EN 50091 and International UPS standard IEC 62040
- Standard back feed protection providing highest safety for working personnel
- Battery earth fault detection increasing the safety of users
- Complete isolation of unit in a parallel system making safe maintenance possible with no interruption to the load

## proven technology

### *Digital Signal Processing*

- Optimised inverter switching
- Lower parts count, higher reliability
- Fast and precise control
- Redundant communication bus

### *Space Vector Modulation*

- Higher accuracy
- Higher and constant efficiency
- Optimised DC (battery) energy use
- Accurate load sharing in parallel operation

## exceptional performance

- High output power factor
  - Excellent dynamic response
  - Strong overload behaviour
- Preventing the need to oversize*

- Low output voltage harmonic distortion
  - High efficiency
- Even at non-linear or partial loads*



# RPA™

## Redundant Parallel Architecture™

GE provides a unique technology called Redundant Parallel Architecture (RPA) that can parallel Uninterruptible Power Supply (UPS) modules with true redundancy. With RPA, there is no need for external electronics or switches to control the UPS modules in the parallel system. One of the UPS modules in the system arbitrarily takes a leadership role, while the other UPS modules have access to all control parameters. If one UPS fails to operate, the load is automatically redistributed among the others. If the lead UPS fails to operate then a different UPS automatically takes on the leadership role. The RPA systems are designed to have no single points of failure, ensuring the highest level of power protection for critical loads.

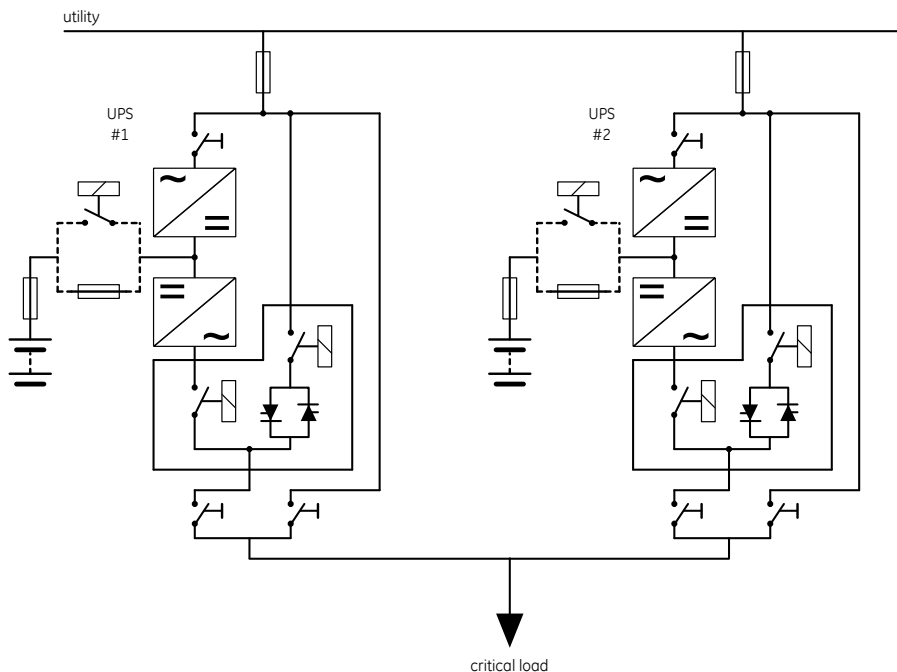

- **RPA Configuration** provides complete redundancy of all critical components and allows paralleling of up to four units for increased load capacity. It ensures excellent dynamic behaviour based on output voltage load sharing. This provides the highest reliability and availability for mission-critical applications.
- **Modular design** allows for system upgrades to meet future power needs without any interruption to the critical load or transfer to bypass.
- **Easy to install and maintain.**
- **Scaleable** design allows for **efficient use of capital.**
- **Redundant** high speed data bus & control electronics facilitates fast decision process with high reliability.
- **Peer-to-Peer architecture** where any UPS can be the “logic leader” ensuring **no single points of failure.**

**a comparative overview**

Multiple UPS are configured in a system to support an increase in load capacity and/or to improve reliability. There are several configurations that include multiple UPS.

**parallel system with automatic transfer switch**

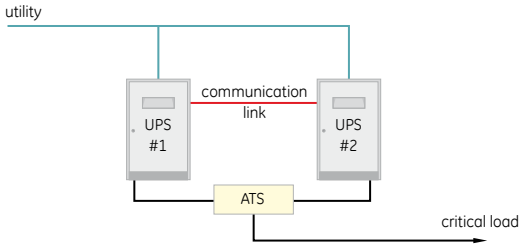

The parallel system with an Automatic Transfer Switch (ATS) consists of one or more UPS modules with outputs connected by a switch that senses a loss in voltage and transfers the load to a different module or modules.

- If one of the UPS modules fails, another unit is available to provide power to the load
- No load sharing
- Additional cost of the ATS
- The ATS is a single point of failure: if it fails, the load will be interrupted even if utility power is available

**parallel system with paralleling cabinet**

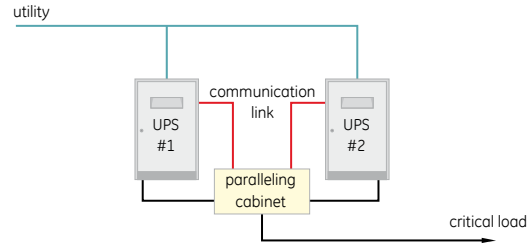

The parallel cabinet configuration uses an external set of centralized electronics to distribute the load between the system's UPS modules.

- No ATS required
- Motor-operated breakers replace the function of the ATS. While less expensive than an ATS, they operate much more slowly
- Failure or malfunction of the shared control electronics will result in a load interruption, which is possible even if the power is present. The shared electronics package is a single point of failure
- Non-redundant communications links
- System price is increased because of the additional cost of the shared control electronics and motor-operated breakers

**hot standby**

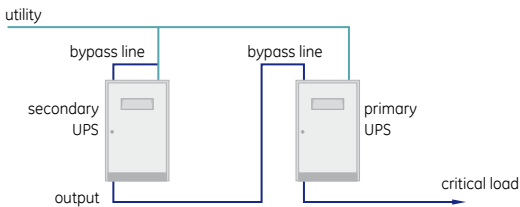

The cascade system or isolated redundant system uses the bypass static switch of the primary UPS to tie the output of a secondary (stand-by) UPS to the load.

- Inexpensive, since no additional components are added to the system
  - There are many single points of failure
  - No sharing of the load. If the primary unit fails, the secondary unit must be able to accept a 100% load increase in 10 milliseconds
  - Overload capacity is limited to the rating of the static switch of the primary module
  - System MTBF\* is typically lower than the MTBF of a single module
- \* Mean Time Between Failures

**parallel system with centralised logic**

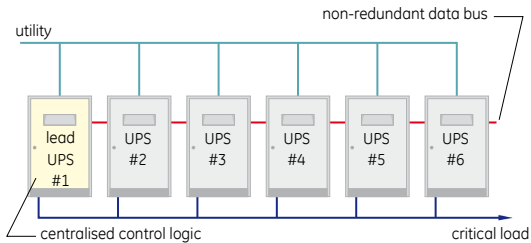

The parallel system with centralised logic is basically designed the same as the paralleling cabinet configuration. The difference is that they utilize the control electronics of one "lead" UPS module to control the distribution of the load between the system's other modules.

- No ATS required
- If the "lead" UPS module fails, the remaining units are uncontrolled. The system may go to bypass on all units, or may stop operation completely
- If the communication link between the lead and other units fails, the load may be interrupted even without a utility power failure

These configurations all share a common shortfall: they all have critical components that are not redundant. GE's RPA™ technology provides complete redundancy of all critical components and there are no single points of failure. RPA technology allows UPS system expansion not only to increase capacity but also to improve the reliability of the power provided to critical loads. For mission critical applications, RPA technology provides true redundancy for the highest reliability.

# IEM™

## Intelligent Energy Management™

GE offers the award-winning Intelligent Energy Management™ (IEM™) capability to optimise energy costs while maintaining the highest possible reliability for parallel redundant UPS systems.

The life cycle cost of a UPS system is built up from different components. In general, approximately half of the total cost is operating cost as a result of energy losses - both direct heat losses in the UPS and indirect energy losses of the air conditioning system.

UPS systems are engineered into applications taking into account the maximum load that needs to be supplied by the system. In practice the UPS will only supply a part of that load for most of the time. Many applications are shut down outside business hours. In addition very often a safety margin is included (over-dimensioning) for future expansion. As a result the system is not used at its nominal rating most of the time during operation. This reduces the efficiency of the system and increases the energy costs.

For parallel UPS installations, secured with RPA™, IEM saves energy by dynamically utilising the UPS modules as required to supply the load without compromising on the power reliability.

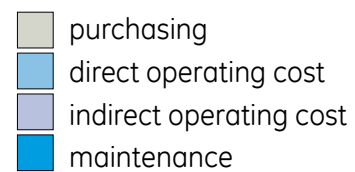
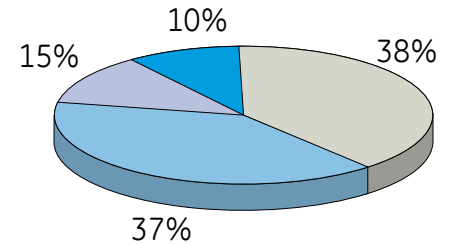

*Typical life cycle cost of a large UPS*

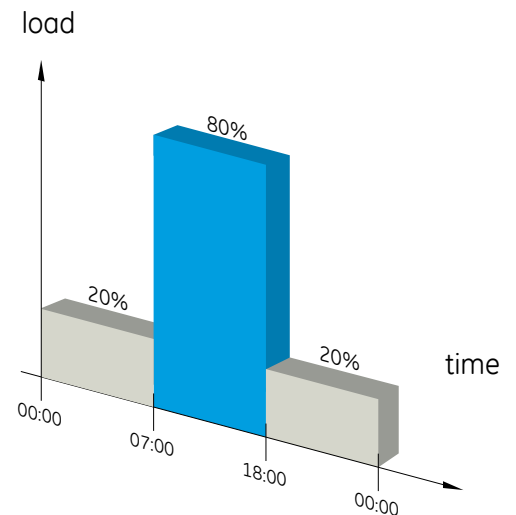

*In a typical application the actual load supplied is generally smaller than the nominal rating of the system*

## legacy parallel system

### full load condition

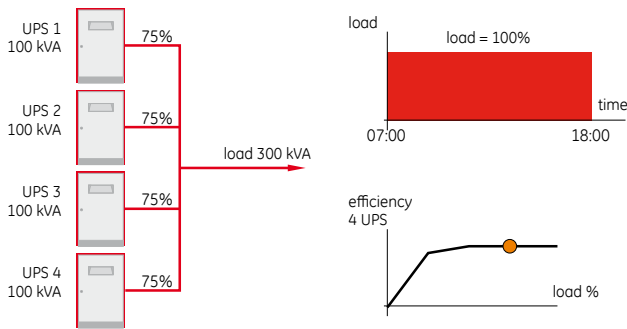

In full load condition the efficiency of a UPS is optimal. However, this condition only occurs typically 10 hours / day

## IEM™ Intelligent Energy Management™

### partial critical load condition with IEM (UPS redundancy)

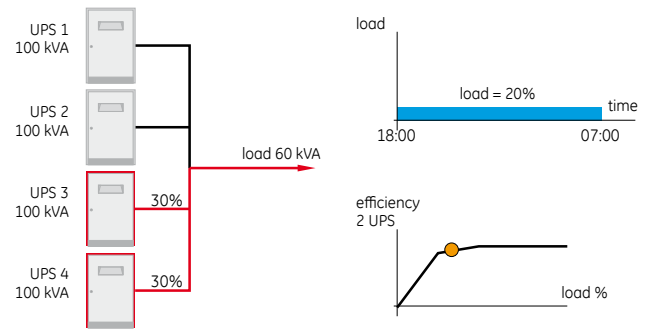

With IEM installed 2 units will be switched off automatically. In this way the efficiency is improved, still maintaining a n+1 redundant system.

### partial-load condition

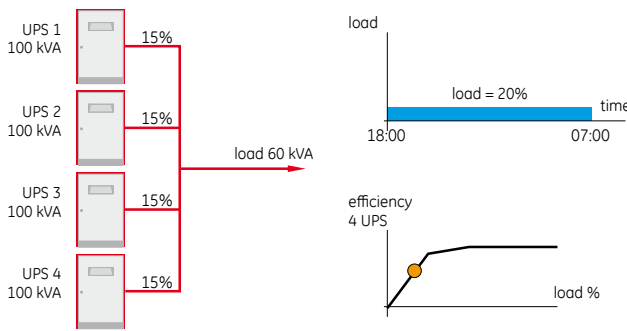

In partial load condition (most of the time) the efficiency of the UPS is lower causing higher energy costs.

### partial non-critical load condition with IEM (utility redundancy)

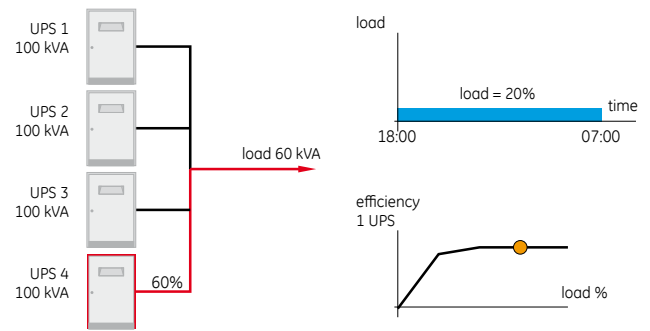

With IEM installed 3 units can be switched off. In this way the efficiency is improved even more. The bypass is still available and will supply the load in case of a failure.

The set-up of IEM™ is flexible, giving the end user the freedom of choice to select redundancy degrees in different time periods. IEM also rotates amongst the units that are switched off to get operating hours equally distributed over all units.

Use of IEM resulted in incremental energy savings of up to \$33,000 annually for a system of four 100kVA units secured by RPA™ operating at full load for 50 hours per week and partial load (10%) for the remaining time.

## benefits

- Reduced energy consumption
- Maintaining of power quality and reliability to the critical load
- Mains power quality monitoring
- User-definable protection levels
- Scheduled activation
- Automatic switch on of additional units in critical situations, increasing reliability
- Equal operating hours for each UPS in a parallel system

# Connectivity solutions

GE Data Protection

## Power Diagnostics

With GE's Power Diagnostics it is possible to combine the remote monitoring and diagnostic core product IRIS web and dedicated services in a comprehensive solution to minimize risk and maintenance costs. 24x7 UPS monitoring, regular operational status reports, immediate alerting for alarms and critical events via SMS, e-mail, fax are just some of the characteristics of the RM&D solution. In particular the system is scalable and can be easily adapted to various configurations, while remaining safe through a multi-level security system.

## Features

### Data transmission

- Data download from GE UPS and 3rd party UPS, via IRIS communication, to GE power diagnostic centre
- Data collection of status values, settings and alarm & event logs
- Alarms and other critical events will be submitted automatically on event, all other values on a regular base (standard weekly)

### Data analysis

- Analysis of available data downloaded from UPS
- Analysis of critical situations, identifying critical trends
- Validating importance and priorities
- Generating status reports
- Preparing maintenance recommendation based on data analysis
- Information will be submitted to client via SMS, email or fax

### Emergency information

- Informing customer about critical situation and faults
- Data are transmitted automatically from UPS to GE power diagnostic centre
- Immediate information sent via SMS, fax, email

### E-Dispatching, intervention

- Send emergency information to local service organisation
- Co-ordination with client to inform that people arrive onsite
- Local service teams will be activated and sent to client site

IRIS offers various communication possibilities: normal phone line, GPRS or SNMP communication, flexible for every requirement.

### Analogue/ISDN modem

- Efficient solution without GPRS functionality using InterLink 2.0 analog
- Can be connected to the UPS during normal UPS operation without any risk
- Less installation time due to an integrated modem

### GPRS

- The best and most efficient solution using InterLink 2.0 GPRS
- Can be connected to the UPS during normal UPS operation without any risk
- Ready to work after connection to UPS and mounting of antenna and power supply
- Best solution where only a small number of UPS are installed on the same site

### SNMP gateway server

- Efficient solution for several UPS on the same site or connected with the same Intranet over SNMP
- Using existing customer intranet and requires an internet connection
- SNMP gateway server will be installed locally to communicate with SNMP cards of UPS
- Secure communication over VPN

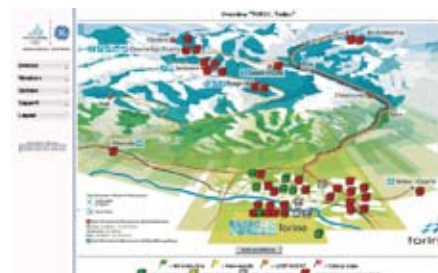

Graphical status overview

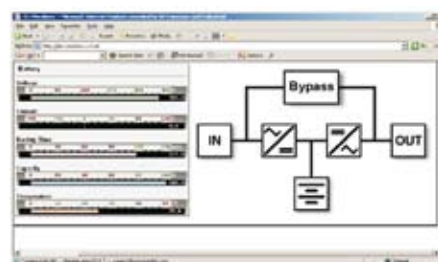

UPS values

## Service for mission critical power

Whether you are a large corporation with multiple sites or a small business owner with a single location, GE will enable you to have a constant supply of clean and reliable power to keep your business up and running. GE offers a comprehensive portfolio of power quality services including:

- UPS installation and start-up, upgrades, spare parts and on-site services
- Battery installation, management and maintenance
- Power grounding
- Harmonic analysis
- Remote monitoring & diagnostics
- Global preventive and corrective services
- Training

### **service coverage**

GE has local offices in a number of countries around the globe and also a network of selected business partners, whose salespeople and service engineers combine expertise in our solutions with an in-depth knowledge of local market conditions. GE's business partners, located in more than 80 countries around the world, use all that expertise and knowledge to adapt GE's products and services precisely to their customers' needs. Supported by highly trained people at our head offices, these business partners are able to provide advice, support and installation 24 hours a day.

# 7x24



# technical specifications

Topology : True on-line, double conversion (VFI) with integral static switch and internal service bypass  
 Technology : Advanced IGBT with SVM strategy, microprocessor controlled at optimal switching frequency  
 Operating Modes : True on-line double conversion, Super ECO Mode, voltage and frequency stabilizer, frequency converter, RPA up to 8 units

Output power rating (kVA)	10	15	20	30	40	60	250	300	400	500	
Output power factor	1	1	1	1	1	0.9	0.9	0.9	0.9	0.9	
Output power rating (kW)	10	15	20	30	40	54	225	270	360	450	
Dimensions (w x d x h, mm)	680x800x1450						*	1550x800x1800		2600x800x1800	
Weight without batteries (kg)	240	290	290	320	350	475	1450	1550	2725	2950	
Audible noise (db(A))	48	50	50	55	60	60	68	68	70	70	
Input voltage	3x380/400/415Vac + N										
Input frequency	50/60 Hz +/- 10%										
Output voltage (sinusoidal)	3x380/400/415Vac + N										
Output frequency	50/60 Hz										
Output distortion at linear load	< 2%										
Output distortion at non-linear load	< 3%										
Crest factor	> 3:1										
Overload capability on inverter	125% 10 min., 150% 1 min. (400-500 kVA 30 sec.)										
Output voltage regulation											
- static	+/-1%										
- dynamic	+/-3%										
Efficiency - double conversion mode	up to 94.5%										
- Super ECO mode	up to 98%										
Backfeed protection	standard										
Ambient operating temperature	0 - 40 °C (32-104 °F)										
Colour	RAL 9003, white										
Protection degree	IP 20										
EMC standards	EN 50091-2 / IEC 62040-2										
Standard interfaces	RS232; 6 programmable alarm contacts										

\* = 750x800x1450

Specifications subject to change without prior notice



your distributor:

GE Consumer & Industrial SA  
 Via Cantonale 50  
 6595 Riazzino (Locarno)  
 Switzerland  
 T +41 (0) 91 850 51 51  
 F +41 (0) 91 850 51 44  
 E gedinfor@ge.com

Visit us online at:  
[www.gedigitalenergy.com](http://www.gedigitalenergy.com)

