



# Digital Energy™ SG-CE Series UPS

80/100/120/160/200/250/300 kVA three phase 400 Vac  
Uninterruptible Power Supply (UPS)



GE imagination at work

For more than a century, GE has led the way with innovative technologies and groundbreaking quality initiatives – literally helping to power the world. Along the way, through the development and delivery of state-of-the-art products and uncompromising service, GE has also built a legacy as a leading supplier of critical power solutions.

To bridge the gap between the traditional utility grid and the needs of today's business, GE offers a complete portfolio of critical power products and services, from desktop Uninterruptible Power Supply (UPS) units to engineered power systems, and from basic UPS and battery maintenance to comprehensive service contracts covering every aspect of your power quality and delivery system.

At GE, our goal is simple – to never let power quality stand in the way of our customers' success. That's why GE is committed to continue developing and delivering

**UPS technology for the digital world**

# The power of GE

GE is a diversified technology and services company dedicated to creating products that make life better from aircraft engines and power generation to financial services, medical imaging, television programming and plastics. GE operates in more than 100 countries and employs more than 315,000 people worldwide.

The company traces its beginnings to Thomas A. Edison, who established Edison Electric Light Company in 1878. In 1892, a merger of Edison General Electric Company and Thomson-Houston Electric Company created General Electric Company. GE is the only company listed in the Dow Jones Industrial Index today that was also included in the original index in 1896.

GE is proud of its impressive track record for introducing leading edge products, accomplishing growth, having strategic customer relationships and a global presence as broad and expansive as its portfolio of products. GE is committed to maintaining a leadership position in all four of its company-wide initiatives (Six Sigma, Globalization, e-Business/Digitization and Services) to achieve maximum results, whilst embracing the values that are at the heart of the business - imagine, solve, build and lead.

## UPS Product Technology

GE is a leader in the field of critical power protection. It's UPS Product Technology business designs, manufactures and delivers premium power quality products and related software products that ensure organisations all over the world enjoy a safe and managed power supply.

Protect your critical power application with a GE UPS – ranging from 350VA to 4MVA. Using state of the art technology GE has developed different UPS with high reliability and maximum application flexibility.

With a GE power solution in place, your mission-critical equipment is protected from any fluctuation in your power source, enabling you to concentrate on your core activities. Leave your critical power needs with GE, a reliable power quality supplier for more than 100 years.



## Digital Energy™ SG-CE Series Uninterruptible Power Supplies 80-300 kVA

The GE Digital Energy™ SG-CE Series is one of the best performing and most reliable three-phase UPS systems providing critical power protection for a wide range of applications. The SG-CE Series operates in VFI mode (Voltage Frequency Independent) and has been developed to satisfy the growing request of Clean Input performances through an innovative control algorithm on the IGBT rectifier power components instead of using standard filters. The Digital Energy SG-CE Series is developed using GE's Design for Six Sigma methodology to ensure that the product fully meets customer requirements and expectations.

The SG-CE Series UPS provides top class reliability and performance. With backfeed protection and compliance to EMC and safety standards the SG-CE Series complies to current standards. Reliability can be further increased by paralleling more units utilising GE's unique RPA™ technology (Redundant Parallel Architecture).

Through their complete life cycle, all GE UPS systems are fully supported by service teams which provide world-class, 24x7 preventive and corrective services, training and application expertise.

### PurePulse™ IGBT rectifier clean input performance

GE's SG-CE Series UPS in the range from 160-300 kVA are available either with traditional thyristor rectifier technology, or with a rectifier based on GE's cutting edge PurePulse™ technology.

PurePulse is an innovative control algorithm applied on the IGBT rectifier. This current source rectifier assures an Input Total Harmonic Distortion (THDi) of less than 2%, and draws a pure sinusoidal waveform from the mains. The advantages of GE's PurePulse technology span from savings in the sizing of upfront equipment (such as generator sets, cabling and circuit breakers) to a total elimination of costs for additional active or passive input filters.

PurePulse is a breakthrough innovation from GE.

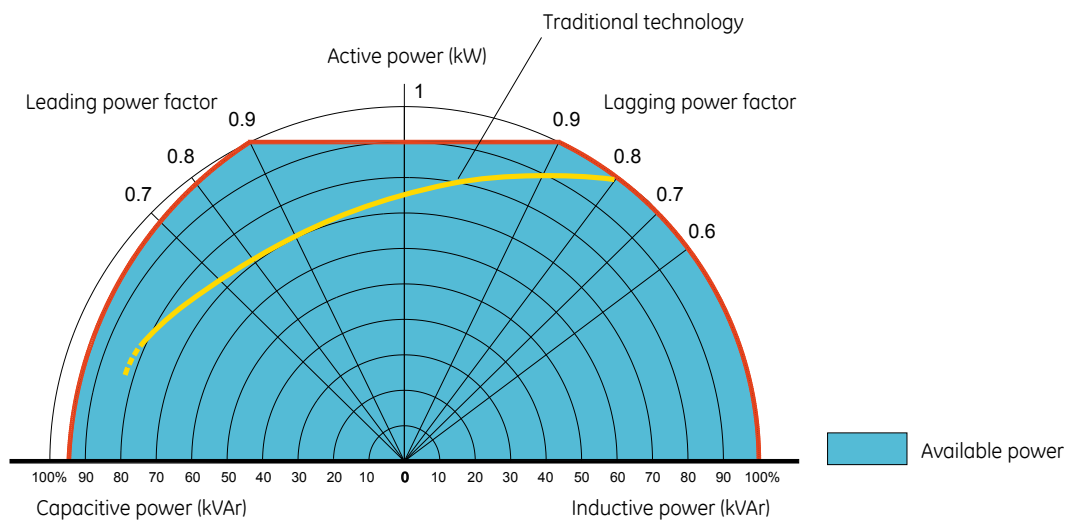

SG-CE Series 160 - 300 kVA power capability

## Available options

- Various battery systems for extended back-up times
- Additional transformers for input/output isolation and voltage adaptation available for all kVA sizes and voltages
- RPA Redundant Parallel Architecture to parallel up to 8 units (80–120 kVA) or up to 6 units (160–300 kVA)
- SNMP plug in card for integration into a computer network
- EMI filter for applications where compliance to EN/IEC62040-2 category C2 (Class A) (EMC std) is required
- Surge suppressors (160–300 kVA)
- ISM Intelligent Synchronisation Module to synchronise the outputs of 2 separate UPS systems
- Halogen free cabling
- Remote monitoring box
- Top entry cables cabinet
- Empty cabinet for special customer application
- Protection degree up to IP31

## Features & benefits

### *Full range:*

- Voltage Frequency Independent (VFI) operation fully compliant with international standards (IEC 62040-3) providing full power protection for demanding critical applications
- Front access for all service and maintenance reducing operational footprint
- Excellent dynamic response preventing the need for oversizing in case of pulsating loads
- Superior Battery Management (SBM) enhances battery lifetime resulting in reduced cost of operation
- Super ECO Mode (user selectable) to reduce energy consumption costs
- Automatic start-up procedure and user friendly interface simplifying UPS operation
- Maintenance bypass integrated in UPS cabinet, no need for external switches
- Fully compliant with EMI international standards (IEC 62040-2) and safety standard (IEC 62040-1)
- Preventative maintenance and advanced diagnostic information using the PMAD feature

### *SG-CE Series 160-300 kVA:*

- Output power factor real 0.9 leading (capacitive loads) provides full power capability and prevents the need to oversize in case of power factor corrected loads
- Fan failure detection system

### *SG-CE Series 160-300 kVA PurePulse™:*

- Innovative IGBT Clean Input Rectifier



# RPA™

## Redundant Parallel Architecture™

GE provides a unique technology called Redundant Parallel Architecture (RPA) that can parallel Uninterruptible Power Supply (UPS) modules with true redundancy. With RPA, there is no need for external electronics or switches to control the UPS modules in the parallel system. One of the UPS modules in the system arbitrarily takes a leadership role, while the other UPS modules have access to all control parameters. If one UPS fails to operate, the load is automatically redistributed among the others. If the lead UPS fails to operate then a different UPS automatically takes on the leadership role. The RPA systems are designed to have no single points of failure, ensuring the highest level of power protection for critical loads.

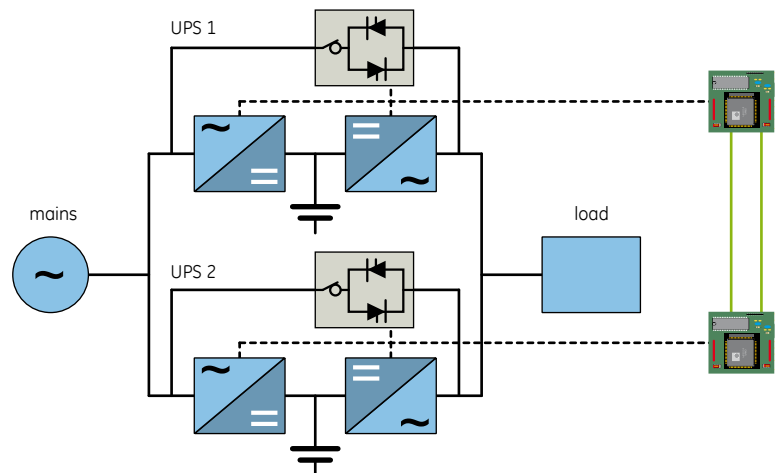

Many other so-called redundant UPS offerings have one critical shortfall, in that they have critical components that are not redundant. RPA technology provides complete redundancy of all critical components and there are no single points of failure. RPA technology allows UPS system expansion not only to increase capacity but also to improve the reliability of the power provided to critical loads. For mission critical applications, RPA technology provides true redundancy for the highest reliability.

- **RPA Configuration** provides complete redundancy of all critical components and allows paralleling more units for increased load capacity. It ensures excellent dynamic behaviour based on output voltage load sharing. This provides the highest reliability and availability for mission-critical applications.
- **Modular design** allows for system upgrades to meet future power needs without any interruption to the critical load or transfer to bypass.
- **Easy to install and maintain.**
- **Scaleable** design allows for **efficient use of capital.**
- **Peer-to-Peer architecture** where any UPS can be the “logic leader” ensuring **no single points of failure.**

# Connectivity solutions

## Power Diagnostics

GE Power Diagnostics is an anytime, anywhere concept in UPS status monitoring and alarm notification that has been successfully implemented in numerous of installations supporting up to multi-hundred UPS.

Based on the leading Intelligent Remote Information System IRIS all GE UPS types as well as 3rd party UPS are supported. Accessing the latest site information via Web and being alerted by Email, SMS or Fax, it enables the user to make timely decisions in case of changing critical conditions.

With comprehensive data collection and analysis IRIS is not only a remote monitoring & diagnostics (RM&D) system but, the core of the integrated service offering GE Power Diagnostics.

## Customer benefits

- 24\*7 remote access to your UPS data using standard web browser
- Automatic alerting in case of event direct and immediately to you cell phone or by email
- Regularly operational reports with proactive information based on data validation from our diagnostics team, analysing
  - Critical trends and probability of future problems
  - Required actions for maintenance or components replacement
- Preventative information using PMAD (Preventative Maintenance & Advanced Diagnostics) feature
- Possibility to reduce intervention and onsite work
  - Remote troubleshooting and online guidance for fault finding
  - Potential to minimize repair times as a result of data analysis. Service team is arriving pre-informed and prepared to solve the problem and is carrying the right spare parts.



Graphical status overview

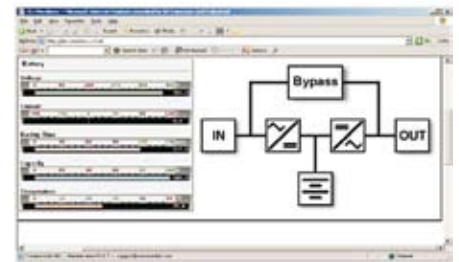

UPS values

## Topologies

IRIS offers various communication possibilities which can be easily combined to match your requirements:

- Analog modem using normal phone line
- GPRS modem using cell phone network
- Network solution using SNMP communication over Ethernet.

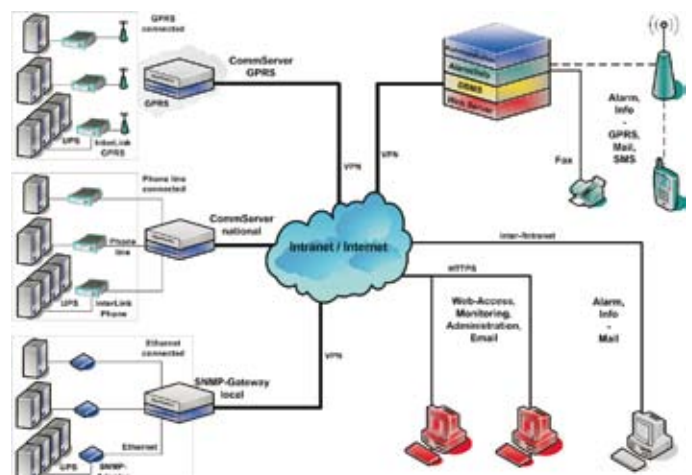

# technical specifications

Topology : VFI (Voltage Frequency Independent) according to IEC 62040-3  
 Operating Modes : Double conversion, automatic bypass, super ECO mode, frequency converter, RPA  
 Standard : ISO 9001, CE Mark, IEC 62040-1, IEC 62040-2, IEC 62040-3, IEC 60950

Output power rating (kVA)	80	100	120	160*	200*	250*	300*
Output power rating (kW)	72	90	108	144	180	225	270
Output power factor	0.9 lagging			0.9 leading / lagging			
Dimensions (w x d x h), mm	800x800x1820	1200x800x1820		1350x850x1900		1500x850x1900	
Weight (kg) [SG-CE Series / SG-CE Series PurePulse™]	605	830	830	1100 / 1225	1150 / 1315	1400 / 1675	1450 / 1775
Audible noise, db(A)	< 65			< 69			
Efficiency (super ECO mode)	up to 98%						
Efficiency	up to 93%			up to 94%			
RPA	up to 8 units			up to 6 units			
Protection degree	IP 20						
Input voltage range	320 - 460 Vac			340 - 460 Vac			
Input frequency range	45 - 65 Hz						
Input current THD	< 6% **			< 2% ***			
Output voltage	3x380/400/415Vac, user selectable						
Output frequency	50/60 Hz +/- 0.01%						
Output voltage THD at linear load	< 1.5%						
Output voltage THD at non-linear load	< 3%						
Output voltage regulation static	< +/- 1%						
Output voltage regulation dynamic (100% step load)	< +/- 2% (recovery time < 5 ms)						
Overload capability on inverter	125% 10 min., 150% 1 min.						
Ambient operating temperature	0 - 40 °C						
Colour	RAL 9003, white						
Safety standards	EN/IEC 62040-1						
EMC standards	EN/IEC 62040-2 (category C2 / Class A optional)						

\* Available with either thyristor or PurePulse IGBT rectifier  
 \*\* If with filters to reduce harmonic distortion of input current  
 \*\*\* If with PurePulse IGBT rectifier

Specifications subject to change without prior notice



your distributor:

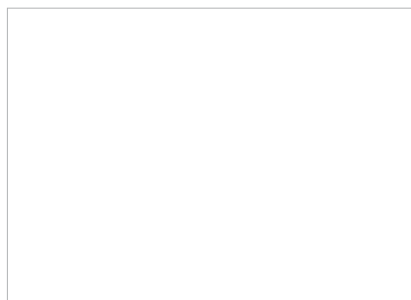

GE Consumer & Industrial SA  
 Via Cantonale 50  
 6595 Riazzino (Locarno)  
 Switzerland  
 T +41 (0) 91 850 51 51  
 F +41 (0) 91 850 51 44  
 E gedeinfo@ge.com

Visit us online at:  
[www.gedigitalenergy.com](http://www.gedigitalenergy.com)

